

# primus

laundry equipment

Xtreme  
in innovation

## Professional Washer Extractors

P 6, P 7



### FEATURES WASHER EXTRACTORS

- Large capacity - 6/7 kg
- Stainless steel cabinet (AISI 304)
- Stainless steel drum and tub
- Easy to use timer, economy programmes, mop programmes
- Short washing cycle
- Large drain valve (Ø50 mm)
- Soap hopper on the front
- Frequency controlled motor
- PowerWash® perforated lifting ribs: more mechanical action, lower water consumption
- SuperEco washing programmes - significantly reduces water and electricity consumption

### OPTIONS WASHER EXTRACTORS

- External coin meter
- Drain pump



COMPACT DESIGN



EASY OPERATION

POWERWASH® superEco

TYPE		P6	P7
CAPACITY	kg/lb	6/15	7,5/18
DRUM DIAMETER	mm	Ø530	Ø530
DRUM VOLUME	l	60	73
MOTOR			
Frequency controlled		standard	standard
EXTRACTION SPEED	rpm	1150	1100
G-FACTOR		390	360
ELECTRICAL CONNECTION		1x220-240V 50/60Hz 3x220-240V 50/60Hz 3x380-415V+N 50/60Hz 1x380-440V 50/60Hz	
ELECTRICAL HEATING	kW	Standard 6kW Optional 3 or 9kW	
WATER CONNECTION			
Warm water max. 70 °C		3/4"	
Cold water connection		3/4"	
DRAIN			
Drain valve		standard	
Pump		available	
DIMENSIONS			
HxWxD	mm	940x685x645	940x685x685
TRANSPORT DATA			
Gross weight			
Foil packing	kg	165	175
Net weight	kg	160	165
Volume (packed)			
Foil packing	m <sup>3</sup>	0,54	0,59
Foil packing			
HxWxD	mm	1060x710x740	1060x710x740
WATER CONSUMPTION			
Cold and hot water per cycle*	l	40+8	48+12

\* Tested in accordance of EN 604 56 norm, The data concerning dimensions of machines include all extended parts

#### P6, P7

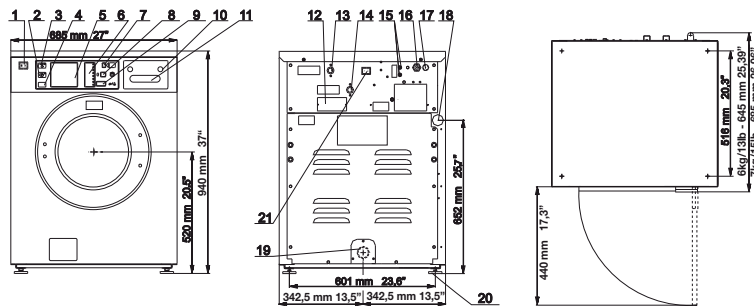

1. Electrical switch
2. Function push button
3. START push button
4. Door open push button
5. Card of programs
6. LED of cycle indicators
7. LED of program display
8. LED of remaining time display
9. LED of option temperature display
10. Soap hopper
11. Drum venting
12. Serial plate
13. Connection of cold water
14. Connection of hot water
15. Fuses
16. Electrical connection of the machine
17. Plug
18. Hose orifice of the version with drain
19. Drain of the version with drain valve
20. Adjustable leg
21. „Program/run“ mode push button

Primus preserves the right to change the machines and the specification in this leaflet at any time, without prior notice. Details and photographs are only for information and never binding.

[www.primuslaundry.com](http://www.primuslaundry.com)

ISO 9001  
ISO 14001  
BUREAU VERITAS  
Certification

