

Xtreme
in innovation

primus

laundry equipment

HIGH EFFICIENT SOFT MOUNTED WASHER EXTRACTORS

FX 65 FX 80 FX 105 FX 135



FEATURES

- Freestanding, high spin (up to 1165 RPM - FX65,80)
- Stainless steel top panel & Anthracite grey front and side panels
- Stainless steel drum and tub
- Xcontrol - easy to use microprocessor
- Patented Soap Hopper
- Large drain valve (Ø 76 mm)
- Easy access to all vital parts from the front
- Large door opening for easy loading & unloading

OPTIONS

- Xcontrol Plus - Fully programmable
- Coin operated timer (CPS)
- Stainless steel front and side panels
- USB plug (on the back panel)
- Easy Soap - liquid soaps connection
- Liquid soap pumps
- Water recovery kit
- Steam heating version
- Drain pump (FX65, 80)
- 3rd water inlet



ERGONOMICAL
CONSTRUCTION



LARGE DOOR
OPENING



LOW WATER AND ENERGY
CONSUMPTION

cascade
drum



superreco

POWERWASH

TRACE-TECH

TYPE		FX 65	FX80	FX105	FX135
INNERDRUM					
maximum capacity 1:9	kg	7	9	12	15
capacity 1:10	kg	6,5	8	11	14
volume	litres	65	75	105	135
diameter	mm	530	530	620	620
DRUM SPEED					
wash	rpm	49	49	49	49
extraction	rpm	1165	1165	1075	1075
G-FACTOR		400	400	400	400
HEATING					
electricity (standard)	kW	6 / 9	6 / 9	6 / 9 / 12	9 / 12
steam	bar	1 - 8	1 - 8	1 - 8	1 - 8
hot water	°C	90	90	90	90
Sound pressure level	dB (A)	< 65	< 65	< 65	< 65
Water valves connection	BSP	3/4"	3/4"	3/4"	3/4"
Water pressure	kPa	100-800	100-800	100-800	100-800
Rec. water pressure	kPa	300-500	300-500	300-500	300-500
Water inlet	l/min	20	20	20	20
Drain valve	outer Ø mm	76	76	76	76
Flow amount with drain valve	l/min	210	210	210	210
Steam valve connection	BSP	1/2"	1/2"	1/2"	1/2"
Steam pressure	kPa	100-800	100-800	100-800	100-800
DIMENSIONS					
Size HxWxD	mm	1115x710x740	1115x710x790	1225x795x795	1225x795x945
TRANSPORT DATA					
Gross	kg	180	200	235	275
Net	kg	170	185	210	255
Packed HxWxD	mm	1245x750x840	1245x750x840	1345x835x840	1345x835x985

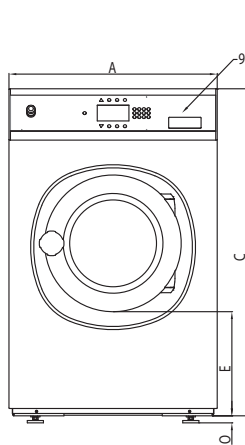

Front side

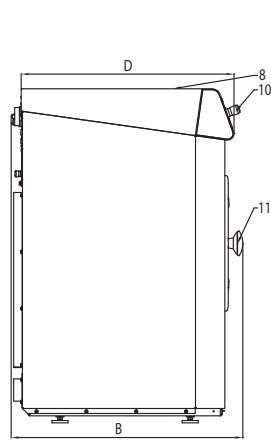

Left side

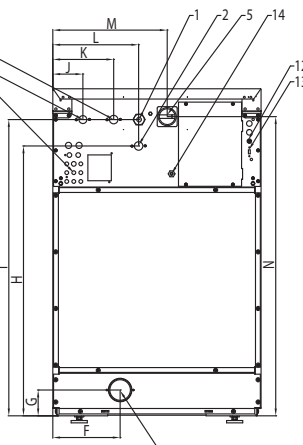

Rear side

- 1 Electrical connection
- 2 Hot water
- 3 Cold water hard
- 4 Cold water soft
- 5 Main switch
- 6 Liquid soap connection
- 7 Drain
- 8 Soap dispenser
- 9 Control panel
- 10 Button CENTRALSTOP
- 11 Door opening, FX65, FX80: Ø 330mm; FX105, FX135: Ø 410mm
- 12 Fuses
- 13 USB port
- 14 Electrical connection to liquid soap pumps

DIMENSIONS

	A	B	C	D	E	F	G	H	I	J	K	L	M	N	O
FX65	710	740	1115	676	349	230	82	914	1004	113	218	293	390	1020	24
FX80	710	790	1115	726	349	230	88	920	1010	113	218	293	390	1020	24
FX105	795	795	1225	761	342	230	88	1030	1120	103	208	293	475	1130	24
FX135	795	945	1225	911	342	230	88	1030	1120	103	208	293	475	1130	24
	width	depth	height												

		FX80
Water consumption	l/kg	7,2
Electricity consumption	kWh/kg	0,19

* Program No 11



WATCH THE FX VIDEO
www.bit.ly/videofx



The company Primus preserves the right to change the machines and the specification in this leaflet at any time, without prior notice. Details and photographs are only for information and never binding.

www.primuslaundry.com

